

Installation and maintenance instructions for Li-Lo Rainwater Underground Tank

1600 L Order No. 200050
3000 L Order No. 200051
5000 L Order No. 200052



The points described in these instructions must be observed under all circumstances. All warranty rights are invalidated in the event of non-observance. Separate installation instructions are enclosed in the transportation packaging for all additional articles purchased from GARANTIA.

Missing instructions must be requested from us immediately.

The tank must be checked for any damage prior to insertion into the trench under all circumstances.

Installation must be carried out by a specialist company.

Table of contents

1.	GENERAL NOTES	2
1.1	Safety	2
1.2	Labelling/Tagging obligation	2
2.	INSTALLATION CONDITIONS	2
2.1	Pedestrian weight resistant	2
2.2	Light traffic load resistant	2
2.3	General	2
3.	TECHNICAL DATA	4
3.1	GARANTIA Li-Lo Rainwater Underground Tank	4
3.2	GARANTIA Teleskopic Dome Shaft	4
3.3	GARANTIA PE Cover	4
3.4	GARANTIA Car Modul	4
4.	TANK STRUCTURE	5
5.	INSTALLATION AND ASSEMBLY	5
5.1	Construction site	6
5.2	Trench	6
5.3	Insertion and filling	7
5.4	Routing connections	7
6.	ASSEMBLING GARANTIA TELESCOPIC DOME SHAFT	8
6.1	Assembly of Teleskopic dome shaft	8
6.2	Assembly of PE Cover	8
6.3	Assembly of Car Modul with cast iron cover (Class B)	8
6.4	Assembling the teleskopic dome shaft as adapter	9
7.	INSPECTION AND SERVICING	9

1. General notes

1.1 Safety

When working, the appropriate accident prevention regulations must be followed (in Germany BGV C22). For safety reasons, especially when entering the tank, it is important that a second person is present.

Furthermore, when carrying out assembly and installation work, inspection, maintenance and repairs, all work regulations and norms must be followed. You will find the advice in the appropriate sections of these instructions.

The installation of the system and/or single equipment parts must be carried out following the enclosed instructions and in a professional manner.

The complete system must always be out of operation and guarded against unauthorized use when carrying out work on the plant or parts of the system.

GARANTIA offers an extensive range of accessories that are all compatible with one another and may be used to construct a complete system. The use of other manufacturers' accessories can impair the function of the system and liability for any resulting damages will no longer be covered under the guarantee.

1.2 Labelling/Tagging obligation

The water in these systems is not suitable for consumption or personal hygiene.

All pipe work and outlets of the water systems are to be labelled with the words "**Not drinking water**" either in words or graphically (German norm DIN 1988 Part 2, paragraph 3.3.2.) so that after years of use, an accidental connection to the drinking water system is excluded. Even when correctly labelled it may possibly be mistaken, for example by children. For this reason, all the outlets of the systems process water must be fitted with **child safe valves**.

2. Installation conditions

2.1 Pedestrian weight resistant

- The GARANTIA Li-Lo Rainwater Underground Tank with the PE cover may only be installed in traffic free areas. The amount of short-term load of the PE cover is max. 150 kg, the long-term area load max. 50 kg.

2.2 Light traffic load resistant

- The GARANTIA Li-Lo Rainwater Underground Tank with the cast iron cover (Class B) and cement support ring are suitable for installation in light traffic areas (max. total load 3.5 ton). The tanks are not to be installed in areas where heavy goods vehicles are driven.
- The areas driven by light traffic must have a compacted earth covering of not less than 700 mm and a maximum of 1000 mm.
- Under no circumstances is the load caused by vehicles to be transferred to the tank.

2.3 General

- In the case of ground water or slope locations the special installation instructions must be followed. (See page 6)
- For installation adjacent to areas traversed by heavy vehicles (See page 6).
- The maximum allowed earth coverage above the tank shoulder must not be more than 1200 mm – in green areas only – not under areas used by passenger cars (See page 3)

2. Installation conditions

Feasible earth coverage height with GARANTIA telescopic dome shaft in green areas.

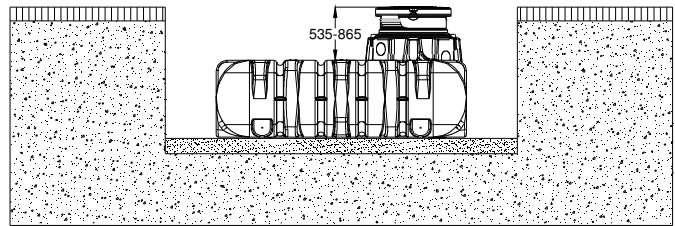

Maximum allowed earth coverage height with second GARANTIA telescopic dome shaft as adapter or extension.

(in green areas only – not under areas used by passenger cars)

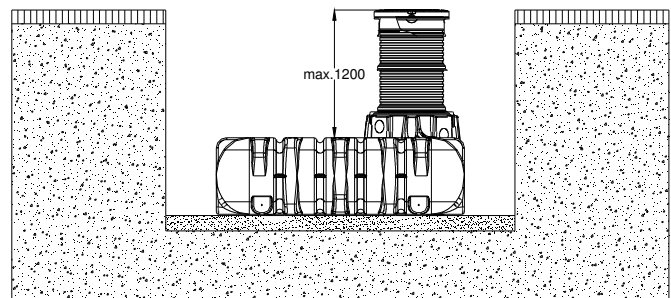

Allowed earth coverage height with GARANTIA telescopic dome shaft and passenger car module with cast iron cover (class B) in areas used by passenger cars (max. total load 3.5 ton).

(without groundwater and stratum water)

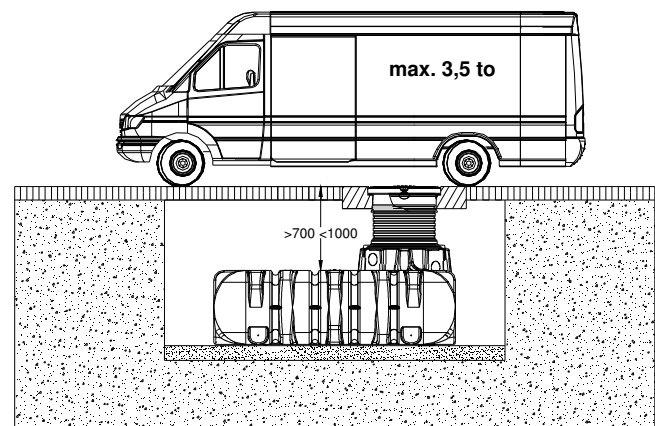

Allowed earth coverage heights on installation in groundwater – the hatched area specifies the permissible immersion depth for the tank.

(not under areas used by passenger cars)

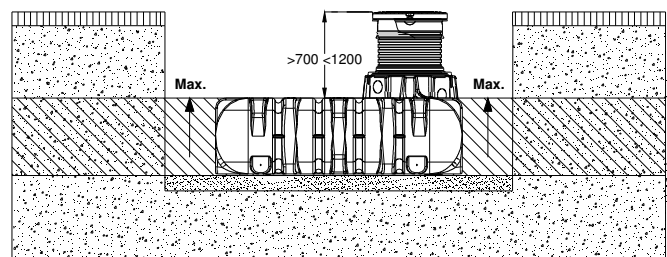

3. Technical data

3.1 GARANTIA Li-Lo Rainwater Underground Tank

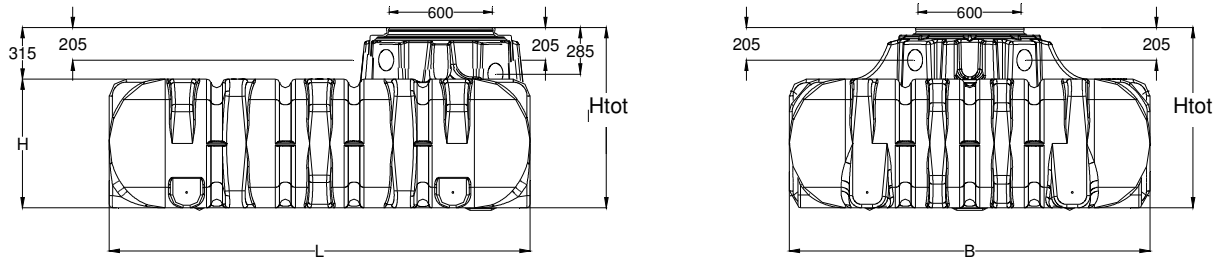

Tank	Order No.	Weight	L	B	H	*Htot
1600 L	200050	80 kg	2100 mm	1250 mm	700 mm	1015 mm
3000 L	200051	170 kg	2450 mm	2100 mm	735 mm	1050 mm
5000 L	200052	240 kg	2890 mm	2300 mm	950 mm	1265 mm

*Htot = total height

3.2 GARANTIA Teleskopik Dome Shaft

(Order No. 202079)

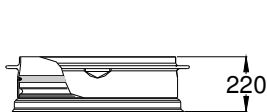

minimum effective length

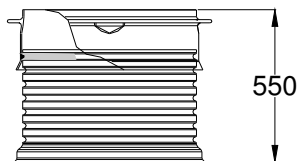

maximum effective length

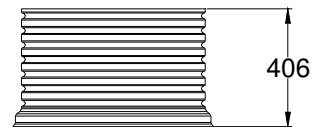

maximum effective length as adapter

3.3 GARANTIA PE Cover

(Order No. 202803)

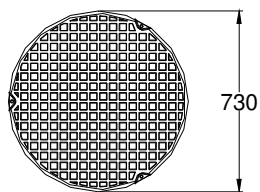

Top view

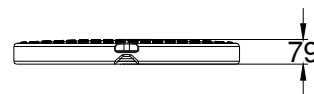

Side view

3.4 GARANTIA Car Modul

(Order No. 202059)

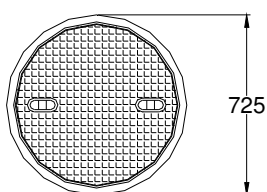

Top view

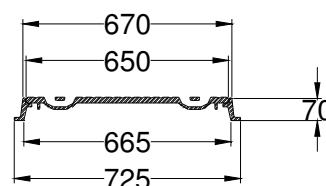

Side view

4. Tank structure

- ① Cover (PE Cover or Car Modul)
- ② Telescopic attachment
- ③ Telescopic conical nipple
- ④ Dome shaft
- ⑤ Li-Lo Rainwater Underground Tank

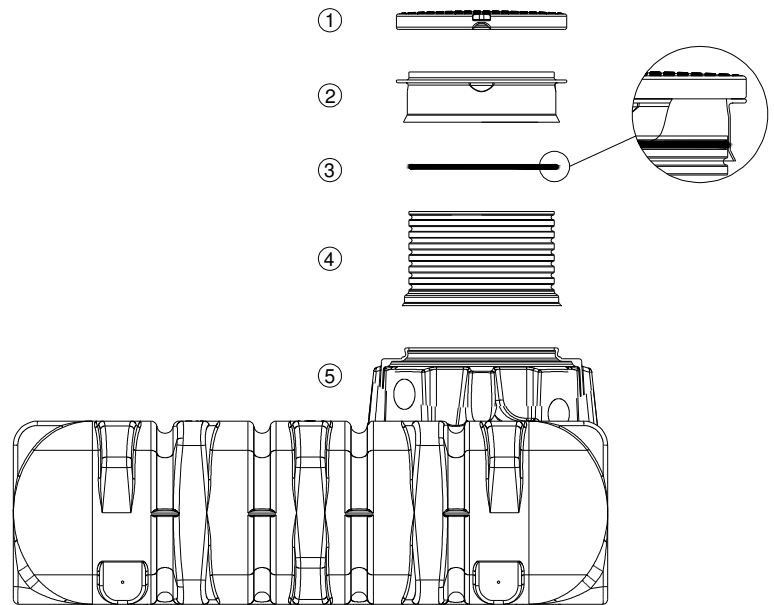

5. Installation and assembly

- ① Subsoil
 - ② Telescopic dome shaft
 - ③ Compacted foundation
 - ④ Surrounding (round-grained gravel, max. grain size 8/16)
 - ⑤ Covering layer
 - ⑥ Li-Lo Rainwater Underground Tank
 - ⑦ Concrete layer for surfaces used by passenger cars
- B** --> DIN 4124 from 1250 mm depth of the trench

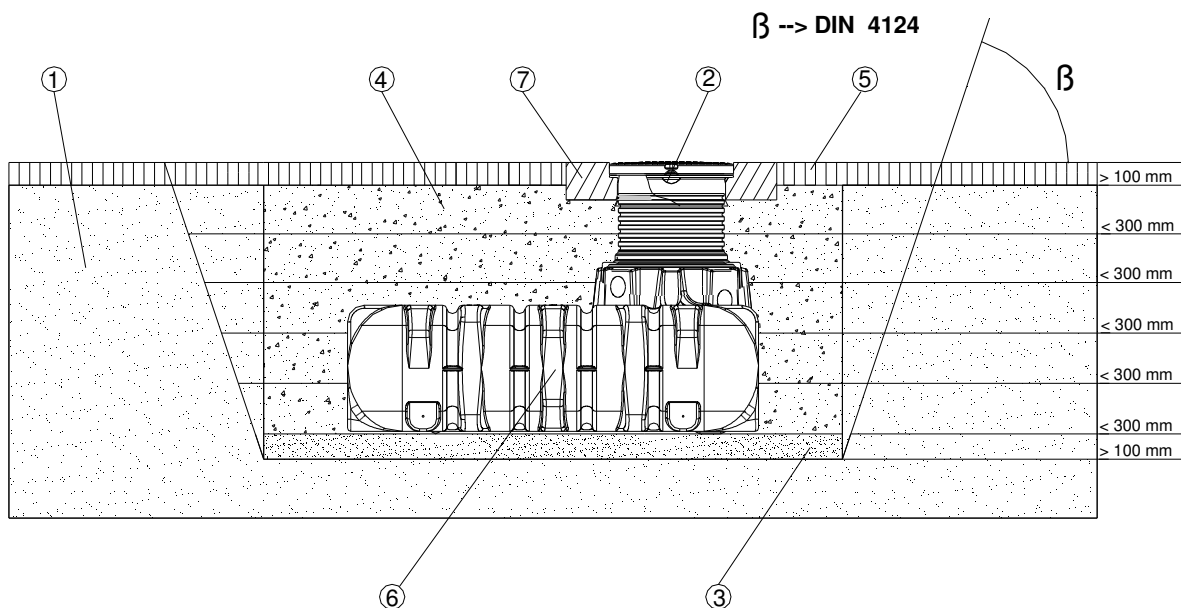

5. Installation and assembly

5.1 Construction site

Under all circumstances, the following points must be clarified prior to installation:

- The structural suitability of the ground according to DIN 18196
- Maximum groundwater levels which occur and drainage capability of the subsoil
- Types of load which occur, e.g. traffic loads

An expert ground report should be requested from the local planning authority to determine the physical characteristics of the subsoil.

5.2 Trench

To ensure that sufficient space is available for working, the base area of the trench must exceed the dimensions of the tank by > 100 mm on each side; the distance from solid constructions must be at least 1000 mm.

If the depth of the trench is > 1250 mm an embankment must be designed according to DIN 4124. The construction site must be horizontal and plane and must guarantee sufficient load-bearing capacity.

The depth of the trench must be dimensioned so that the max. earth coverage (see point 2 – installation conditions) above the tank is not exceeded. To use the system throughout the entire year, it is necessary to install the tank and those parts of the system which conduct water in the frost-free area. The frost-free depth is usually approx. 600 mm – 800 mm; precise information in this regard can be obtained from the responsible authority.

A layer of compacted, round-grain gravel (grain size 8/16, thickness approx. 100 - 150 mm) is applied as the foundation.

5.2.1 Slope, embankment, etc.

On installation of the tank in the immediate vicinity (< 5 m) of a slope, earthen mound or slope, a statically calculated supporting wall must be erected to absorb the soil pressure. The wall must exceed the dimensions of the tank by at least 500 mm in all directions, and must be located at least 1000 mm away from the tank.

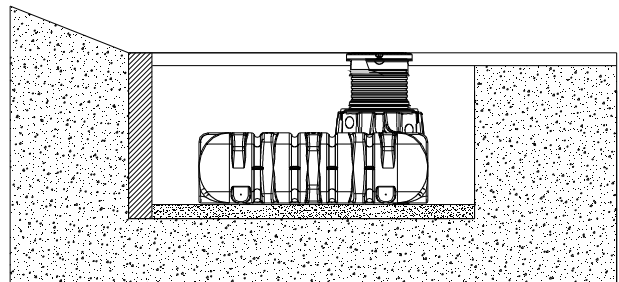

5.2.2 Groundwater and cohesive (water-impermeable) soils (e.g. clay soil)

If it is anticipated that the tanks will be immersed deeper into the groundwater than is shown in the adjacent figure, sufficient dissipation must be ensured. (See table for max. immersion depth).

Dissipation of the drainage water (e.g. via an annular drainage system) is recommended in the case of cohesive, water-impermeable soils.

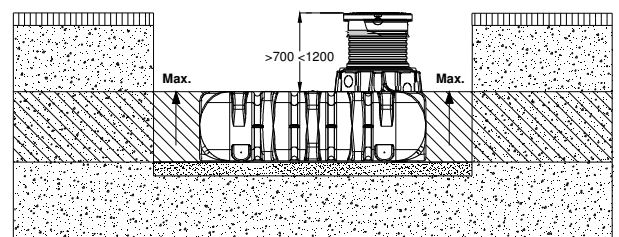

1600L -> 700mm / 3000L -> 735mm / 5000L -> 950mm

5.2.3 Installation adjacent to surfaces used by vehicles

If the underground tanks are installed adjacent to surfaces which are used by heavy vehicles weighing over 3.5 ton, the minimum distance away from these surfaces is at least the depth of the trench.

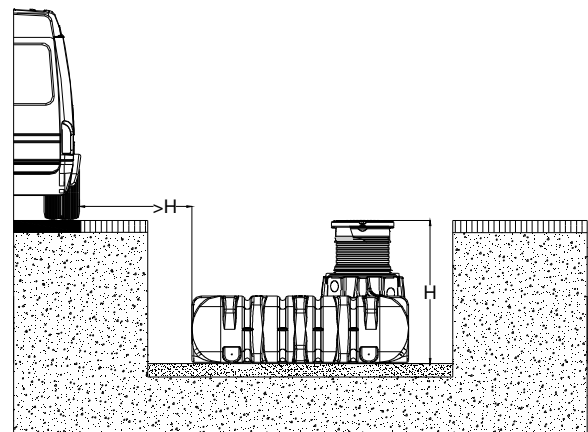

5. Installation and assembly

5.2.4 Connection of several tanks

Two or more tanks are connected via the assembly surfaces by means of GARANTIA special seals and basic pipes (to be provided at construction site).

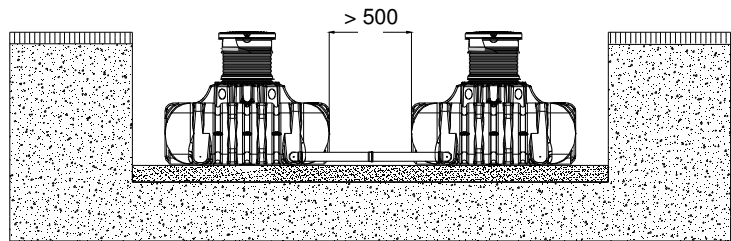

The apertures must be drilled to the corresponding size using only the GARANTIA special crown bit. It must be ensured that the distance between the tanks is at least 500 mm. The pipes must project at least 200 mm into the tanks.

5.3 Insertion and filling

The tanks must be inserted, impact-free, into the prepared trench using suitable equipment. To avoid deformities, the tank is filled 1/3 with water before filling in the tank surrounding.

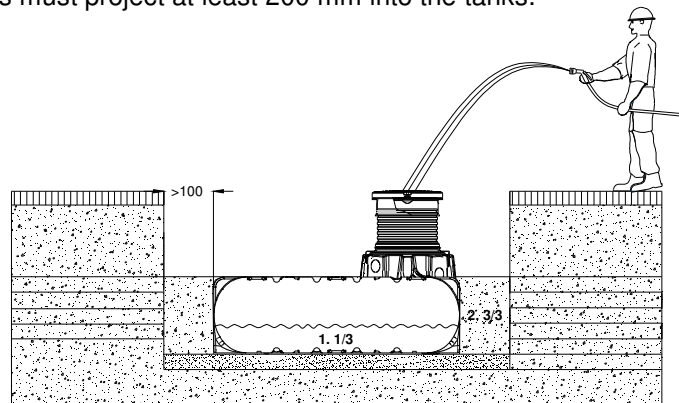

Afterwards the surrounding (roundgrain gravel, max. grain size 8/16) is then filled in layers of max. 30 cm steps and is compacted.

The individual layers as well as the medial support column must be well-compacted (manuel tamper). Damage to the tank must be avoided during compaction. Mechanical compaction machines must not be used under any circumstances. The surrounding towards the trench must be at least 100 mm wide.

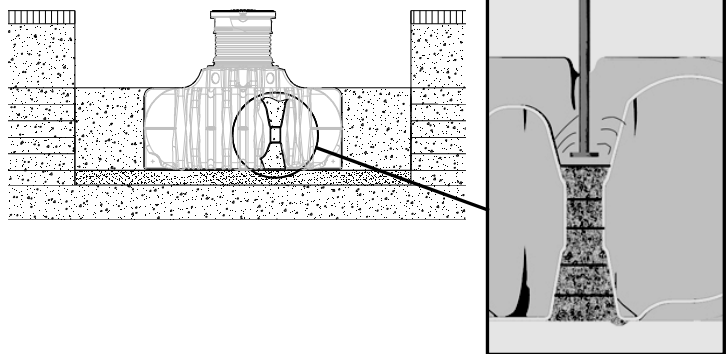

5.4 Routing connections

All feed and overflow pipes must be routed with a decline of at least 1% in the direction of flow (possible, subsequent settling must be taken into consideration in this case). If the tank overflow is connected to a public sewer, this must be protected against reflux by means of a lifting station (mixed sewer) or reflux seal (pure rainwater sewer) according to DIN 1986.

All suction, pressure and control lines must be routed in an empty pipe, which must be routed as straight as possible, without bending, to the tank with a decline. Necessary bends must be formed using 30° moulded sections.

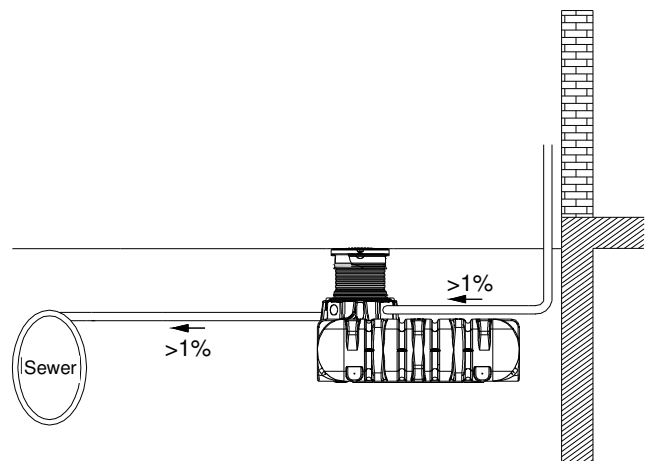

Important: The empty pipe must be connected to an aperture **above** the max. water level.

6. Assembling GARANTIA Telescopic Dome Shaft

6.1 Assembly of Telescopic dome shaft

The telescopic dome shaft enables infinite adaptation of the tank to the given site surfaces between min. 535 mm and max. 865 mm. The telescopic dome shaft has 7 positions in 50 mm steps (see sketch). To allow the minimum soil covering of the tanks of only 535 mm, the telescopic attachment must be slightly shortened.

The sealing ring is placed in the highest remaining complete groove and the telescopic attachment is pushed on (first lubricate the sealing ring). The telescopic attachment must be well supported with back fill material to ensure that it will not sink when under load.

For assembling, the telescopic dome shaft is placed loosely on the tank opening. It gains its final stability without further fastening when the pit is filled up and compressed.

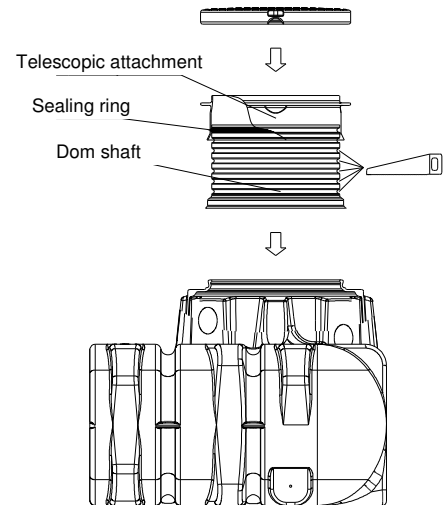

6.2 Assembly of PE Cover

The PE Cover must remain locked (child proof) in position except when working in the tank.

The three sleeves are guided and hammered from below into the holes of the telescopic attachment and screwed from above with 5 - 6 turns. Finally place the cover in position and screw into place so that it is child proof. The washers prevent the screws from cutting into plastic material of the cover.

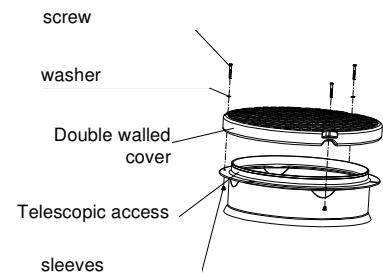

6.3 Assembly of Car Modul with cast iron cover (Class B)

When the tank is installed in areas traversed by light traffic (max. total load 3.5 ton) the telescopic assembly must be embedded and supported by reinforced concrete (Load classification B25 = 250 Kg/m²). The concrete encasement must be uninterrupted, 300 mm wide and approximately 200 mm deep. Subsequently, the concrete frame as well as the cast iron cover (class B) supplied with the product are fitted. The earth covering above the tank must be not less than 700 mm and a maximum of 1000 mm.

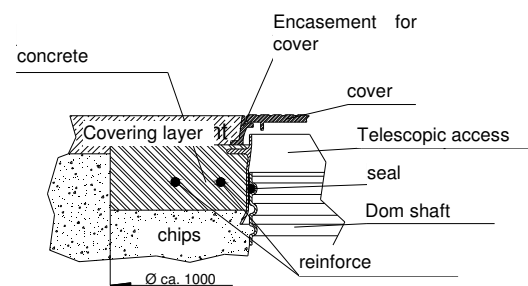

Under no circumstances are ensuing loads to be transferred directly to the tank.

The Li-Lo Rainwater Underground Tank may under no circumstances be installed in areas traversed by heavy goods vehicles or heavy machinery (See point 5.2.3).

6. Assembling GARANTIA Telescopic Dome Shaft

6.4 Assembling the telescopic dome shaft as adapter

If a wider dome shaft ③ is used as shaft extension or adapter for larger earth coverage, it is fitted loosely between the tank opening ④ and the top telescopic dome shaft ②. The shaft extension gains its final stability without further fastening when the pit is filled up and compressed.

The maximum effective length per shaft extension or adapter is 406 mm. The dome shaft can be shortened at 7 positions from top by 50 mm in each case (see sketch).

The maximum allowed earth coverage height in combination with a second GARANTIA Telescopic Dome Shaft as adapter or extension is 1200 mm above tank shoulder (only in green areas – not in the areas used by passenger cars).

Adapter = Max. effective length 406 mm

Allowed earth coverage height = Max. 1200 mm above tank shoulder

- ① Cover (PE Cover or Car Modul)
- ② Teleskopic Dome Shaft
- ③ Dome shaft (shaft extension or adapter)
- ④ Li-Lo Rainwater Underground Tank

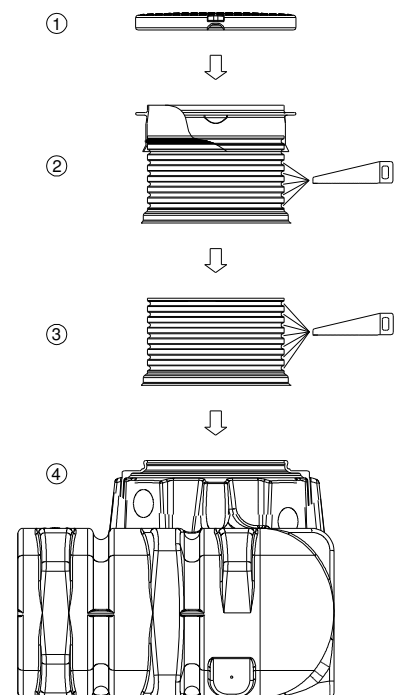

7. Inspection and servicing

The entire system must be checked for leaks, cleanliness and stability at least every three months.

The entire system should be serviced at intervals of approx. 5 years. In this case, all parts of the system must be cleaned and their function checked. Servicing should be carried out as follows:

- Drain the tank completely
- Clean surfaces and internal parts with water
- Remove all dirt from the tank
- Check that all internal parts are firmly seated.

Garantia®, a trademark of Otto Graf GmbH

Otto Graf GmbH – Carl-Zeiss-Str. 2-6 – D-79331 Teningen – Tel.: +49 (0) 76 41/58 9-0 – Fax: +49 (0) 76 41/58 9-50
GRAF SARL – 45, Route d’Ernolsheim – F-67120 Dachstein Gare – Tel.: +33 (0) 3 88 49 73 10 – Fax: +33 (0) 3 88 49 32 80
GRAF Iberica – C/Marquès Caldes de Montbui, 114 baixos – ES-17003 Girona – Tel.: +34/972 913 767 – Fax: +34/972 913 766
GRAF Ltd – Maidstone, Kent – UK-ME16 8Ry – Phone: +44 (0) 16 22 68 65 50